

ITEM NO.	PART NUMBER	DESCRIPTION	QTY.
1	100-05651	SPRING HANGER	2
2	100-05869	FENDER BRACKET	2
3	221-00014	ANGLE	1

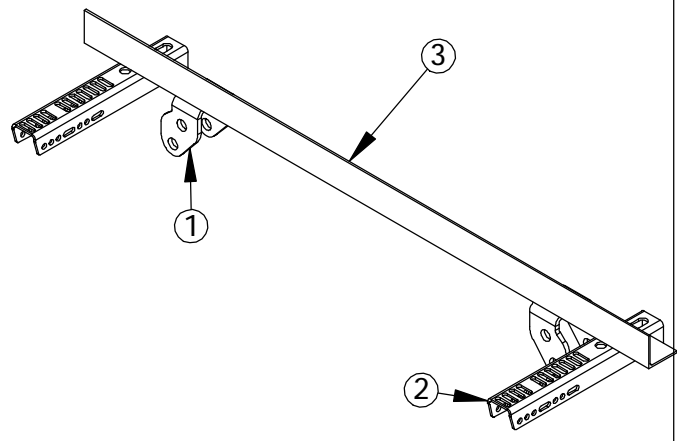

VIEW A

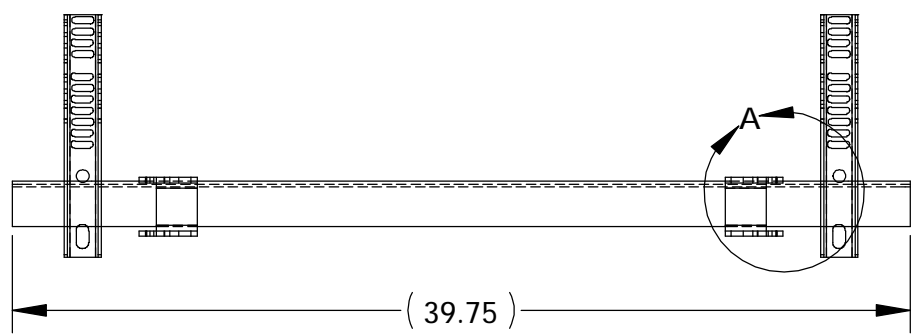
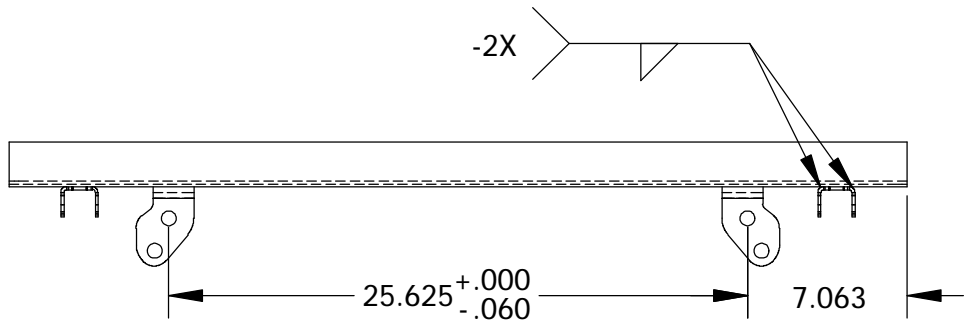
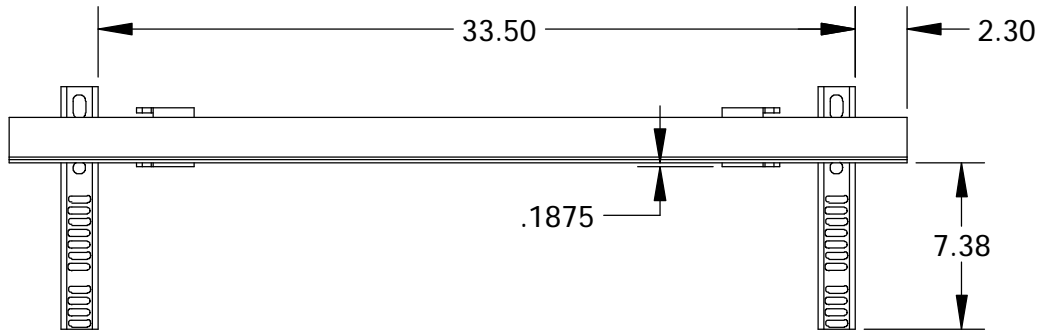
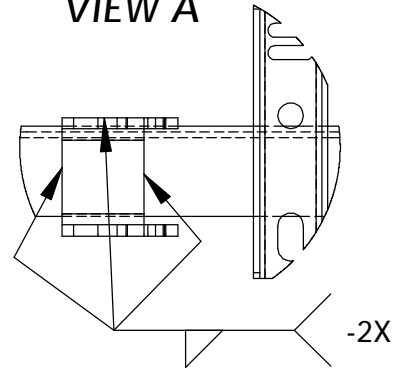

ALL DIMENSIONS ARE IN INCHES
UNLESS OTHERWISE STATED
TOLERANCES EXCEPT AS NOTED
DECIMALS:
.X ±0.100
.XX ±0.060
.XXX ±0.030
.XXXX ±0.010
ANGLES:
±1°
ALL FORMED ANGLES
EQUAL 90° UNLESS
NOTED OTHERWISE
() INDICATES REFERENCE

THE INFORMATION IN THIS DRAWING IS THE SOLE
PROPERTY OF KARAVAN TRAILERS, INC. ANY
REPRODUCTION IN PART OR WHOLE WITHOUT
THE WRITTEN PERMISSION OF KARAVAN TRAILERS,
INC. IS PROHIBITED.
APPROVED BY:
DRAWN BY:
JOEL NEHRING
DATE:
12-16-14
SHEET:
1 OF 1
SCALE:
N/A

KARAVAN
TITLE:
SPRING HANGER WELDMENT
(13" FENDER FOR 14" TIRE)
MAT'L:
SEE B.O.M.
FINISH:
-BL, -BT, -GL
DWG. #:
300-03353-A

DWG. REV.	ECR/NDR NUMBER	REVISED BY	DATE	DESCRIPTION
A	15741	JRN	12-16-14	DRAWING CREATED

First Piece - In Process Inspection Sheet

Vendor _____

Description: **Spring Hanger Weldment**

Part # **300-03353**

Rev. **A**

QA Approval: K. Hopf

JOB# _____

Characteristic	Tol.	Method	Freq.	1st Piece	A/R	2	A/R	3	A/R	4	A/R	5	A/R	6	A/R	7	A/R	Inspected By:	
33.50	± .060	Tape	2X per shift																1 /
2.30	± .060	Tape	2X per shift																2 /
.1875	± .060	Tape	2X per shift																3 /
7.38	± .060	Tape	2X per shift																4 /
25.625	+ .000 - .060	Tape	2X per shift																5 /
7.063	± .060	Tape	2X per shift																6 /
Weld per print	NA	Visual	Every piece																7 /
Remove all visible weld spatter	NA	Visual	Every piece																