

NOTE:

- 1.) AT BASE OF LEGS, 3.020 +.024/-0.000
- 2.) BREAK ALL SHARP CORNERS .060
- 3.) WALL THICKNESS .250 ±.007 UNLESS OTHERWISE STATED.
- 4.) WEIGHT/FT: 6.34 LBS.
- 5.) PART TO BE DEBURRED

ALL DIMENSIONS ARE IN INCHES
UNLESS OTHERWISE STATED
TOLERANCES EXCEPT AS NOTED

DECIMALS:
 .X ±0.100
 .XX ±0.060
 .XXX ±0.030
 .XXXX ±0.010

ANGLES:
 ±1°
 ALL FORMED ANGLES
 EQUAL 90° UNLESS
 NOTED OTHERWISE

() INDICATES REFERENCE

THE INFORMATION IN THIS DRAWING IS THE SOLE
PROPERTY OF KARAVAN TRAILERS, INC. ANY
REPRODUCTION IN PART OR WHOLE WITHOUT
THE WRITTEN PERMISSION OF KARAVAN TRAILERS,
INC. IS PROHIBITED.

APPROVED BY:

DRAWN BY:
Amy L. Groth

DATE:
11-14-03

SHEET:
1 OF 2

SCALE:
N/A



TITLE:
BUNK BRACKET
(3" X 3" CROSSMEMBER)

MAT'L:
6005-T5 OR 6105-T5

FINISH:
N/A

DWG. #:
227-00186

C/4	14171	KDB	06-27-07	CHANGED TOLERANCE ON THE 3.020 DIM TO .064 FROM .040
C/3	13888	KDB	12-18-06	PART TO BE DEBURRED
DWG. REV.	ECR/NDR NUMBER	REVISED BY	DATE	DESCRIPTION

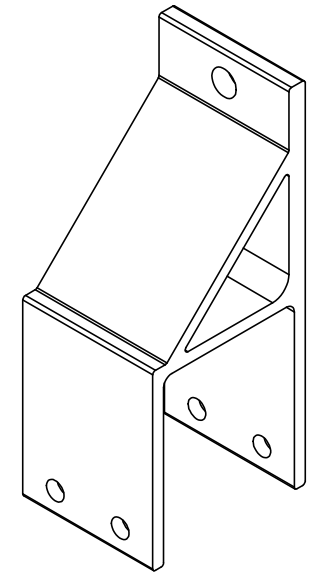
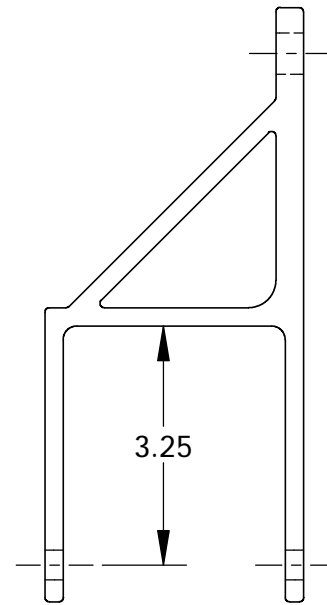
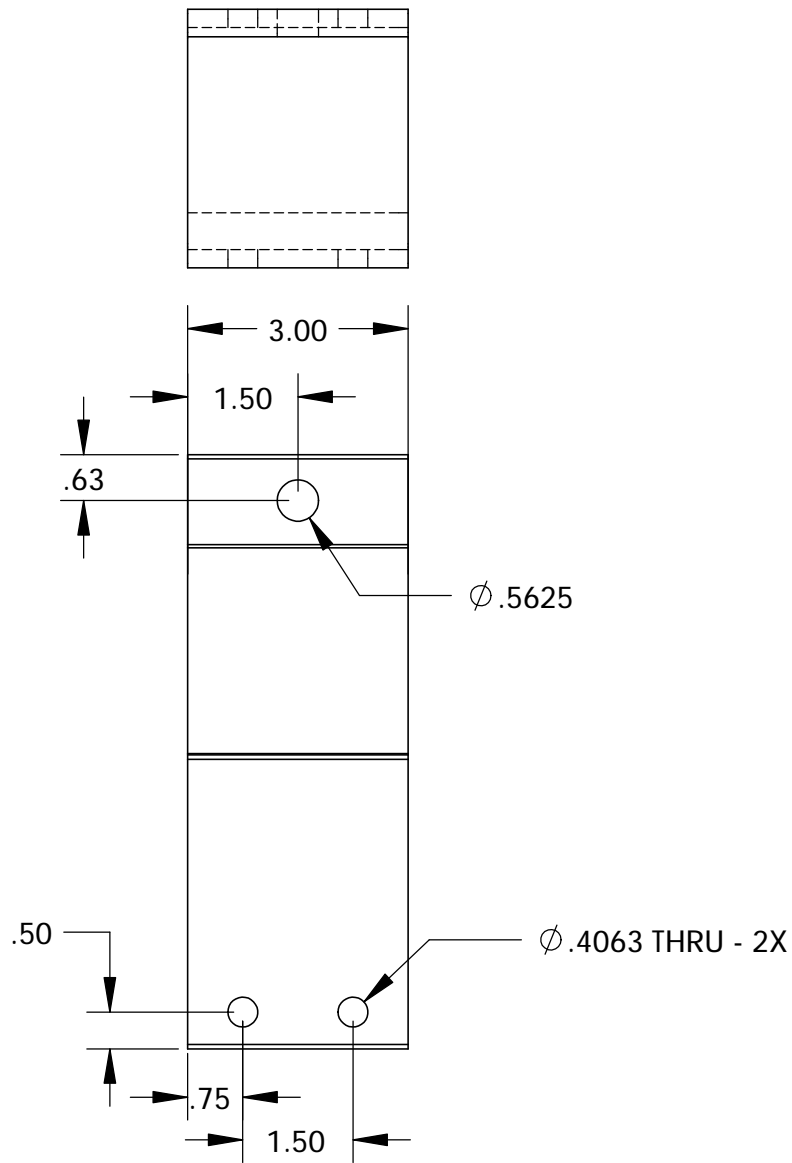

ALL DIMENSIONS ARE IN INCHES
UNLESS OTHERWISE STATED
TOLERANCES EXCEPT AS NOTED

DECIMALS:
 .X ±0.100
 .XX ±0.060
 .XXX ±0.030
 .XXXX ±0.010

ANGLES:
 ±1°
 ALL FORMED ANGLES
 EQUAL 90° UNLESS
 NOTED OTHERWISE

() INDICATES REFERENCE

THE INFORMATION IN THIS DRAWING IS THE SOLE
PROPERTY OF KARAVAN TRAILERS, INC. ANY
REPRODUCTION IN PART OR WHOLE WITHOUT
THE WRITTEN PERMISSION OF KARAVAN TRAILERS,
INC. IS PROHIBITED.

APPROVED BY:

DRAWN BY:
Amy L. Groth

DATE:
11-14-03

SHEET:
2 OF 2

SCALE:
N/A



TITLE:
BUNK BRACKET
(3" X 3" CROSSMEMBER)

MAT'L:
6005-T5 OR 6105-T5

FINISH:
N/A

DWG. #:
227-00186

DWG. REV.	ECR/NDR NUMBER	REVISED BY	DATE	DESCRIPTION
C/4	14171	KDB	06-27-07	CHANGED TOLERANCE ON THE 3.020 DIM TO .064 FROM .040
C/3	13888	KDB	12-18-06	PART TO BE DEBURRED