

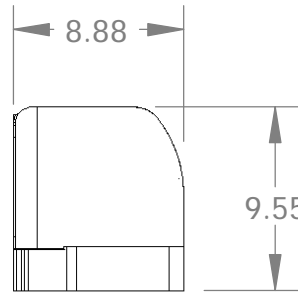

KARAVAN P/N	SUPPLIER P/N	QTY. PER BOX	REQUIRES ISPM-15 COMPLIANT PALLET
206-00085	206-00085	100	NO
206-00085(80)M 	206-00085(80)M	80	YES
206-00085(100)M 	206-00085(100)M	100	YES
206-00085 (MEX) 	206-00085 (MEX)	80	YES

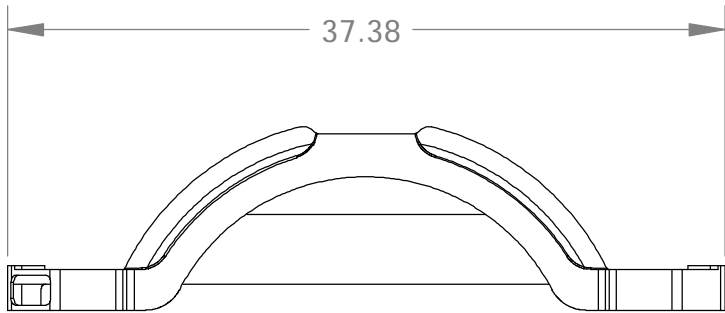

'MARK' LOCATIONS FOR SHIPPING PALLET WHEN REQUIRED TO BE ISPM-15 COMPLIANT

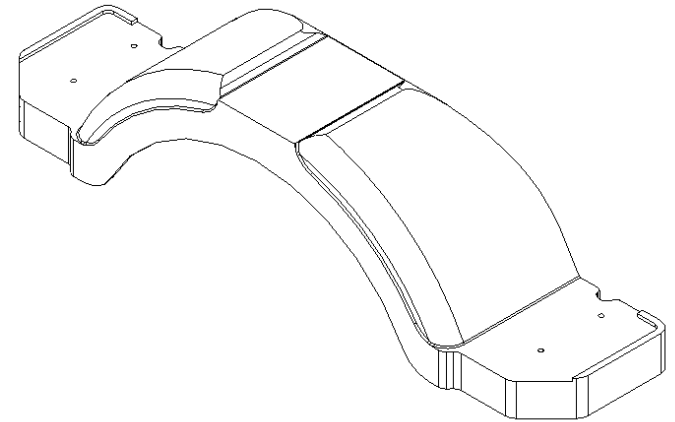
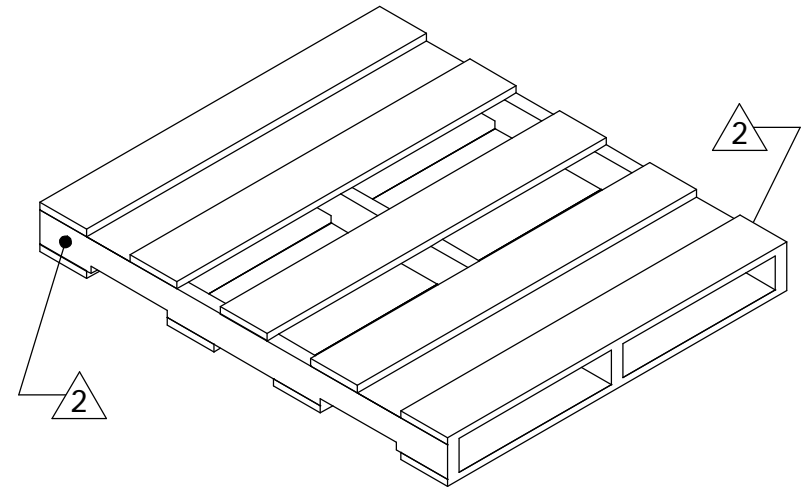

NOTE:
1.) MATERIAL: POLYPROPYLENE.

 THESE PARTS ARE REQUIRED TO HAVE A PALLET THAT IS COMPLIANT TO THE LATEST ISPM-15 (INTERNATIONAL STANDARDS FOR PHYTOSANITARY MEASURES) AND BARE 'MARKING FOR APPROVED MEASURES' ON TWO VISABLE SURFACES, OPPISITE OF EACH OTHER.

ALL DIMENSIONS ARE IN INCHES UNLESS OTHERWISE STATED TOLERANCES EXCEPT AS NOTED

DECIMALS:

.X ±0.100
.XX ±0.060
.XXX ±0.030
.XXXX ±0.010

ANGLES:

±1°
ALL FORMED ANGLES EQUAL 90° UNLESS NOTED OTHERWISE

() INDICATES REFERENCE

THE INFORMATION IN THIS DRAWING IS THE SOLE PROPERTY OF KARAVAN TRAILERS, INC. ANY REPRODUCTION IN PART OR WHOLE WITHOUT THE WRITTEN PERMISSION OF KARAVAN TRAILERS, INC. IS PROHIBITED.

APPROVED BY:

DRAWN BY:
JUSTIN D. SCHMIDT

DATE:
05-05-05

SHEET:
1 OF 2

SCALE:
N/A

KARAVAN
TRAILERS

TITLE:
12" FENDER W/STEP L.H.
(NO LOGO)

MAT'L:
PURCHASED

FINISH:
-WH, -GR, -BL, -BN, -SS, -OR, BLW

DWG. #:
206-00085-B

DWG. REV.	ECR/NDR NUMBER	REVISED BY	DATE	DESCRIPTION
B	15342	KMH	08-04-11	Ø.2570 THRU - 4X WAS Ø.22 - 4X
A/4	15056	RJS	03-01-10	ADDED 206-00085(MEX) TO REFERENCE BLOCK

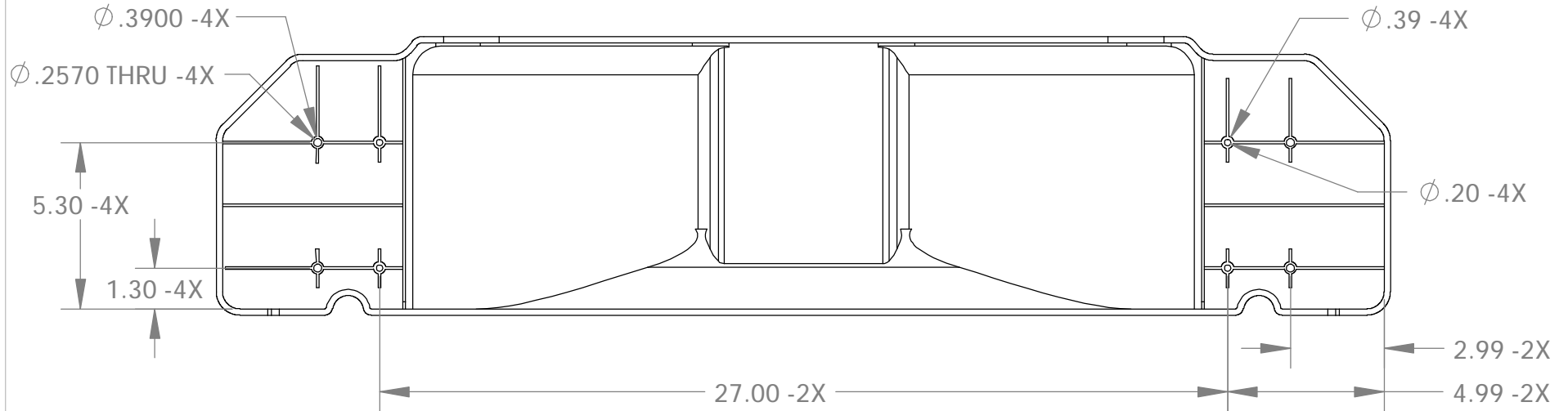
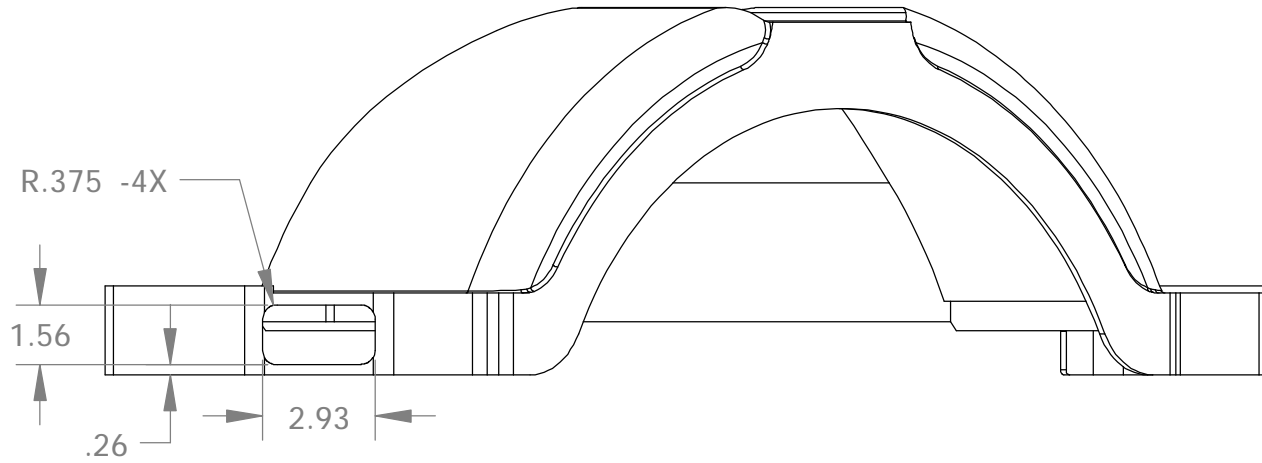

NOTE:
1.) MATERIAL: POLYPROPYLENE.

DWG. REV.	ECR/NDR NUMBER	REVISED BY	DATE	DESCRIPTION
B	15342	KMH	08-04-11	Ø.2570 THRU - 4X WAS Ø.22 - 4X
A/4	15056	RJS	03-01-10	ADDED 206-00085(MEX) TO REFERENCE BLOCK

ALL DIMENSIONS ARE IN INCHES
UNLESS OTHERWISE STATED
TOLERANCES EXCEPT AS NOTED

DECIMALS:
.X ±0.100
.XX ±0.060
.XXX ±0.030
.XXXX ±0.010

ANGLES:
±1°
ALL FORMED ANGLES
EQUAL 90° UNLESS
NOTED OTHERWISE

() INDICATES REFERENCE

THE INFORMATION IN THIS DRAWING IS THE SOLE
PROPERTY OF KARAVAN TRAILERS, INC. ANY
REPRODUCTION IN PART OR WHOLE WITHOUT
THE WRITTEN PERMISSION OF KARAVAN TRAILERS,
INC. IS PROHIBITED.

APPROVED BY:

DRAWN BY:
JUSTIN D. SCHMIDT

DATE:
05-05-05

SHEET:
2 OF 2

SCALE:
N/A

KARAVAN
TRAILERS

TITLE:
12" FENDER W/STEP L.H.
(NO LOGO)

MAT'L:
PURCHASED

FINISH:
-WH, -GR, -BL, -BN, -SS, -OR, BLW

DWG. #:
206-00085-B