

# FLAT VIEW

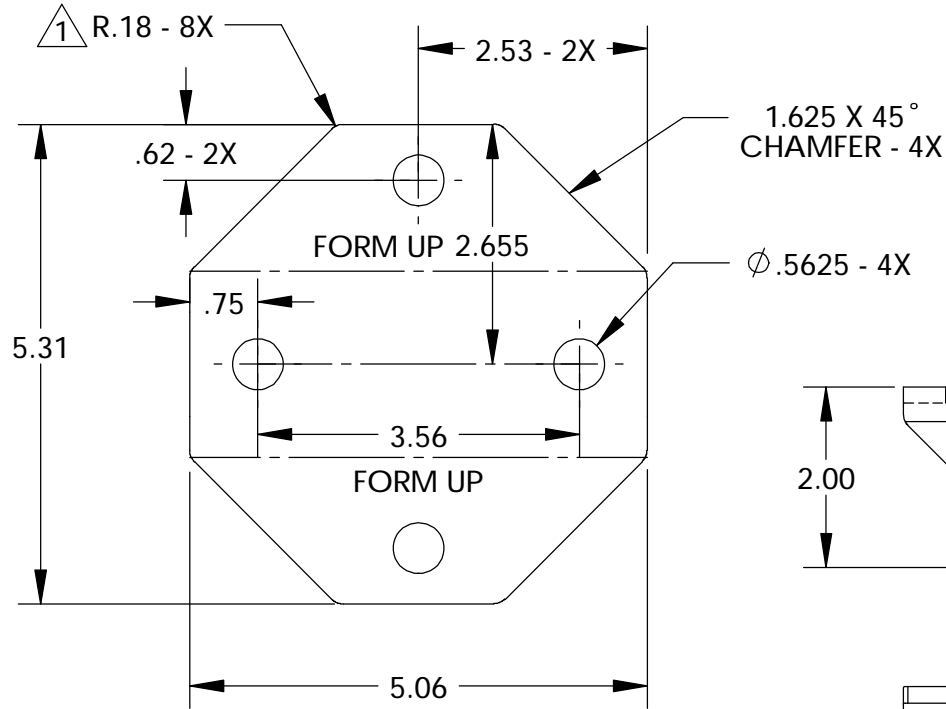

# FORMED VIEWS

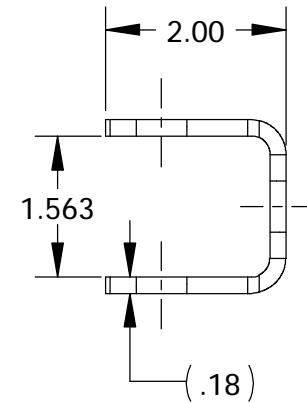
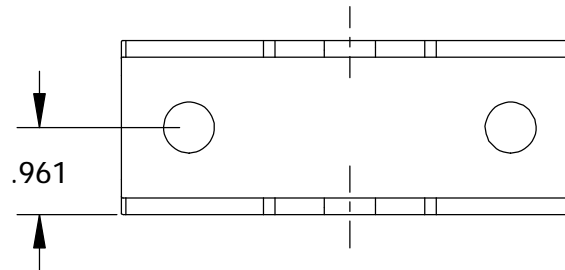
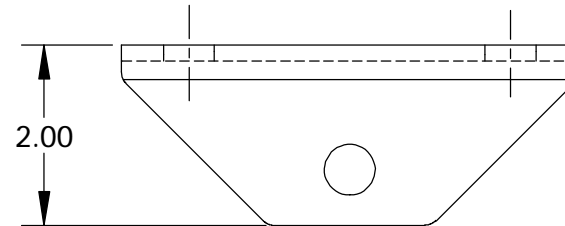
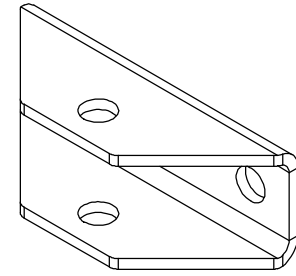

### NOTES:

$\triangle 1$  RADIUS OR SQUARE CORNER ACCEPTABLE

ALL DIMENSIONS ARE IN INCHES  
 UNLESS OTHERWISE STATED  
 TOLERANCES EXCEPT AS NOTED  
 DECIMALS:  
 .X  $\pm 0.100$   
 .XX  $\pm 0.060$   
 .XXX  $\pm 0.030$   
 .XXXX  $\pm 0.010$

ANGLES:  
 $\pm 1^\circ$   
 ALL FORMED ANGLES  
 EQUAL  $90^\circ$  UNLESS  
 NOTED OTHERWISE

( ) INDICATES REFERENCE

THE INFORMATION IN THIS DRAWING IS THE SOLE  
 PROPERTY OF KARAVAN TRAILERS, INC. ANY  
 REPRODUCTION IN PART OR WHOLE WITHOUT  
 THE WRITTEN PERMISSION OF KARAVAN TRAILERS,  
 INC. IS PROHIBITED.

APPROVED BY:  
 CRICHTER

DRAWN BY:  
 Amy L. Thomas

DATE:  
 12-03-99

SHEET:  
 1 OF 1

SCALE:  
 N/A

# KARAVAN

TITLE:  
 BUNK BRACKET  
 (2.00" PIVOT)

MAT'L:  
 7GA H.R.P.O. SHEET

FINISH:  
 -Z

DWG. #:  
 100-01297

DWG. REV.	ECR/NDR NUMBER	REVISED BY	DATE	DESCRIPTION
B/1	14150	KDB	07-16-07	ADDED CORNER NOTE
B	12073	DWG	10-16-01	5.31 WAS 5.42, .961 WAS 1.023, AND 1.563 WAS 1.688

### First Piece - In Process Inspection Sheet

Vendor \_\_\_\_\_

Description: **Bunk Bracket**

Part # **100-01297**

Rev. **B/1**

QA Approval: Doug Dray

JOB# \_\_\_\_\_

Characteristic	Tol.	Method	Freq.	1st Piece	A/R	2	A/R	3	A/R	4	A/R	5	A/R	6	A/R	7	A/R	Inspected By/Date:	
<b>PUNCH</b>																			
7 GA.	.171-.187	Mic	1:100															1	/
H.R.P.O	NA	Visual	-															3	/
5.31	±.060	Caliper	1:100															4	/
5.06	±.060	Csliper	1:100															5	/
Ø.5625 - 4X	±.010	Caliper	1:100															6	/
2.53 - 2X	±.060	Csliper	1:100															7	/
.62 - 2X	±.060	Csliper	1:100																
.75	±.030	Csliper	1:100																
3.56	±.060	Csliper	1:100																
1.625 X 45° Chamfer - 4X	±1°	Protractor	1:100																
R.18 - 8X	±.030	Caliper	1:100																
<b>FORM</b>																			
90°	±1°	Protractor	1:100																
2.00	±.060	Caliper	1:100																
.961	±.030	Caliper	1:100																
1.563	±.030	Caliper	1:100																
Inspect parts for scratches, dents, gouges, etc.	NA	Visual	Every piece																